

EN580E.ML-SC10.GB11G.13120.H

Solid shaft with clamping flange, optical multiturn encoders 13 bit ST / 12 bit MT, SSI

Article number: 11246026

Overview

- Absolute encoder multiturn
- Optical sensing method
- Resolution: singleturn 13 bit, multiturn 12 bit
- Clamping flange
- Maximum resistant against magnetic fields
- Connection: flange connector M23, 12-pin, CCW



Technical data

Technical data - electrical ratings

Voltage supply	8...30 VDC
Reverse polarity protection	Yes
Short-circuit proof	Yes
Consumption w/o load	≤80 mA (24 VDC)
Interface	SSI
Function	Multiturn
Steps per revolution	8192 / 13 bit
Number of revolutions	4096 / 12 bit
Absolute accuracy	±0.03 °
Sensing method	Optical
Code	Gray
Code sequence	CW: ascending values with clockwise sense of rotation; looking at flange
Input signals	SSI clock Zero setting input Counting direction
Output stages	SSI data: Linedriver RS422
Output signals	SSI data
Interference immunity	EN 61000-6-2

Technical data - electrical ratings

Emitted interference	EN 61000-6-4
Approval	UL Class 2
Technical data - mechanical design	
Size (flange)	ø58 mm
Shaft type	ø10 x 20 mm, solid shaft with flat
Flange	Clamping flange
Protection EN 60529	IP 54 (flange side) IP 65 (housing side)
Operating speed	≤6000 rpm (+25 °C)
Starting torque	≤0.02 Nm
Admitted shaft load	≤40 N axial ≤80 N radial
Material	Housing: aluminium Shaft: stainless steel
Operating temperature	-25...+85 °C (see general information)
Relative humidity	95 % non-condensing
Resistance	EN 60068-2-6 Vibration 30 g, 10-2000 Hz EN 60068-2-27 Shock 100 g, 6 ms
Weight approx.	400 g
Connection	Flange connector M23, 12-pin, CCW

General information

Self-heating correlated to installation and ambient conditions as well as to electronics and supply voltage must be considered for precise thermal dimensioning. Operating the encoder close to the maximum limits requires measuring the real prevailing temperature at the encoder flange.

Terminal assignment

Flange socket M23, 12-pin, male contact, CCW

Pin	Assignment
1	Data-
2	-
3	SET
4	DIR
5	Clock+
6	Clock-
7	-
8	Data+
9	-
10	0 V
11	-
12	+Vs

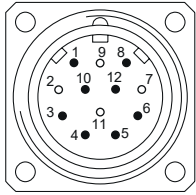

Terminal significance

SET	Zero setting input. Input for zero setting at any position. The zero setting operation is triggered by a high pulse and has to be in line with the selected direction of rotation (DIR). Impulse duration >100 ms. Connect to 0 V after zero setting for maximum interference immunity.
DIR	Counting direction input. This input is standard on high. DIR-High means ascending output data with clockwise shaft rotation when looking at flange. DIR-Low means ascending values with counterclockwise shaft rotation when looking at flange. For maximum interference immunity connect to +Vs respectively 0 V depending on counting direction.

Trigger level

SSI	Circuit
SSI-Clock	RS422 with terminating resistor 120 Ω
SSI-Data	RS422

Control inputs	Input circuit
Input level High	>0.7 UB
Input level Low	<0.3 UB
Input resistance	10 kΩ

Data transfer

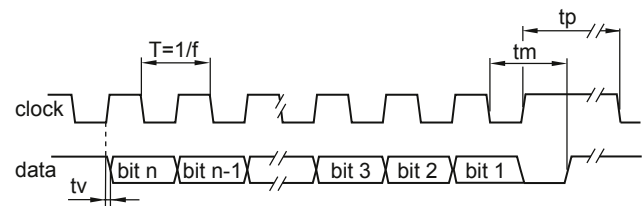

Clock frequency f	80...2000 kHz
Delay time tv	70 ns (RL = 120 Ohm)
Monoflop time tm	16 ... 24 μs + T/2
Clock interval tp	30 μs

EN580E.ML-SC10.GB11G.13120.H

Solid shaft with clamping flange, optical multiturn encoders 13 bit ST / 12 bit MT, SSI

Article number: 11246026

Dimensions

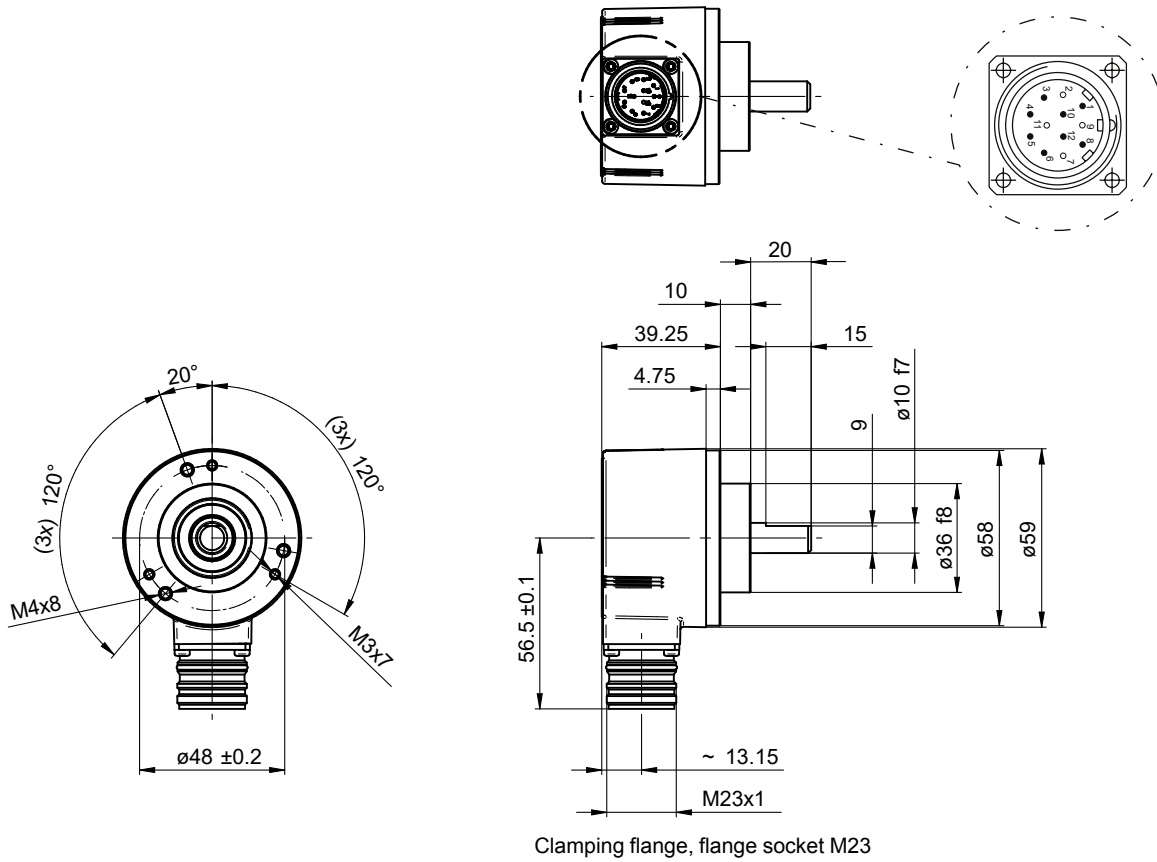

EN580E.ML-SC10.GB11G.13120.H

Solid shaft with clamping flange, optical multiturn encoders 13 bit ST / 12 bit MT, SSI

Article number: 11246026

Accessories

Mounting accessories

11101781	Double loops coupling (D1=10 / D2=10)
11050507	Bellows coupling aluminium/stainless steel D1=06 / D2=10
11065923	Coupling CPS25 L=19 d1=10/d2=10
11065922	Coupling CPS25 L=19 d1=10/d2=06
10141132	Spring washer coupling D1=6 / D2=10
10141133	Spring washer coupling D1=10 / D2=10
11069337	Coupling CPS37 L=24 d1=10/d2=06
11069340	Coupling CPS37 L=24 d1=10/d2=10
11053277	Bellows coupling aluminium/stainless steel 10 mm
11101893	Spring encoder arm
10125051	Mounting adaptor for encoders with clamping flange (M3) (Z 119.017)