

Process displays

For standard signals, strain gauge

PA440



PA440 - Process display

Technical data - electrical ratings

Voltage supply	24/115/230 VAC ±10 % (50/60 Hz) 10...30 VDC
Power consumption	15 VA, 10 W
Sensor supply	Optionally selectable: 24 V / max. 30 mA (non-regulated) 10 V ±50 mV / 120 mA (adjustable by potentiometer, default) 5 V ±50 mV / 120 mA (adjustable by potentiometer) 2.2 V / 30 mA
Display	LED, 7-segment display (with 100 unit stickers for front)
Number of digits	5-digits + activity indicator
Digit height	14 mm
Display range	-9999...9999 ("oUFLo" to signal overflow)
Display refresh	100 ms
Function	Digital display of 1 analog measured value, With Min/ Max memory and tare function, Volume calculation functions, Totaliser and batch counter
A/D transformer	Principle $\Sigma\Delta$ Resolution 16 bit Measuring rate 555/s Measuring accuracy ±(0.1 % +2-digit) Temp. coeffic. 50 ppm/°C
Analog input	Current, voltage, potentiometer, strain gauge

Features

- Current / voltage input or strain gauge
- Totaliser, batch counter
- Programmable characteristic curve with 30 control points
- Volume calculation functions
- High measuring rate 555/s
- Min, Max, Tare functions
- Analog output 4...20 mA or 0...10 V
- Interface RS232 or RS485
- DIN housing 96 x 48 mm

Technical data - electrical ratings

Programmable parameters	Measuring range Display range can be linearised Decimal point Relay or electronic outputs with time delay or hysteresis Analog output Analog input Volume calculation Control inputs
Limits	Without, 2, 4
Control inputs	4 inputs NPN, max. 40 V (20 mA)
Control functions	34 programmable functions
Data memory	>10 years in EEPROM
Outputs electronic	Optocoupler PNP (optional)
Analog output	Current or voltage
Outputs relay	2x change-over contact, floating, or 4x normally open
Interfaces	RS232, RS485
Profiles	ASCII, ISO1745, Modbus RTU
Transmission rate	=19.2 kBaud
Standard DIN EN 61010-1	Protection class II Overvoltage category II Pollution degree 2
Emitted interference	DIN EN 61000-6-3
Interference immunity	DIN EN 61000-6-2

Process displays

For standard signals, strain gauge

PA440

Part number

PA440. **AX01**

- | | |
|---|---|
| | Voltage supply |
| 1 | 24 VAC |
| 3 | 115 VAC |
| 4 | 230 VAC |
| 5 | 10...30 VDC |
| | Relay outputs / Analog output |
| 0 | Without outputs |
| 1 | Two relay outputs |
| 2 | Four relay outputs |
| 3 | Four electronic outputs PNP |
| 5 | Analog output 4...20 mA / 0...10 V |
| 6 | Two relay outputs and analog output
4...20 mA / 0...10 V |
| 7 | Four relay outputs and analog output
4...20 mA / 0...10 V |
| 8 | Four electronic outputs PNP and analog
output 4...20 mA / 0...10 V |
| | Interface |
| 0 | Without interface |
| 1 | RS485 |
| 2 | RS232 |

Accessories

Mounting accessories

ZPA4.002 Accessory for DIN rail mounting (ZPA4.002)

Technical data - mechanical design

Ambient temperature	-10...+60 °C
Storage temperature	-25...+85 °C
Relative humidity	95 % non-condensing
Connection	Spring-loaded terminal connector, detachable
Core cross-section	1 mm ² (Grid 5.08) 2.5 mm ² (Grid 7.62)
Protection DIN EN 60529	IP 65 (face)
Operation / keypad	Membrane with softkeys
Housing type	Built-in housing
Dimensions W x H x L	96 x 48 x 127 mm
Cutout dimensions	92 x 45 mm (+0.3)
Mounting depth	150 mm
Mounting type	Front panel installation by clip frame
Weight approx.	600 g
Material	Housing: Polycarbonate, UL 94V-0

Connection diagram

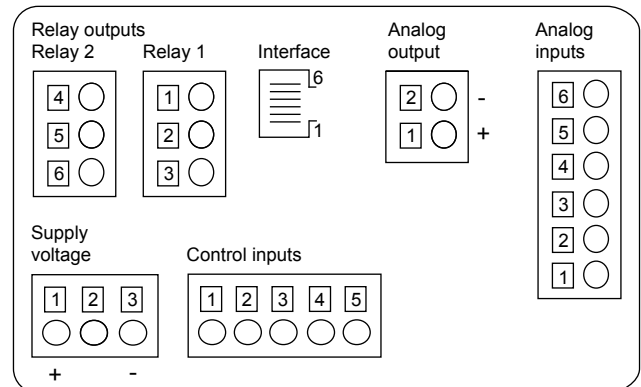

Process displays

For standard signals, strain gauge

PA440

Inputs and outputs

Analog input

Input	Range	Resolution	Specification
Current	±20 mA	1 µA	Input resistance 11.8 Ω
Voltage	±1 V ±5 V ±10 V	1 mV	Input resistance 100 MΩ Input resistance 1 MΩ Input resistance 1 MΩ
Potentiometer voltage*	2.2 V		Input resistance 10 MΩ
Strain gauge	±30 mV, ±60 mV, ±120 mV, ±300 mV, ±500 mV	1 µV	Input resistance 100 MΩ

*Minimum potentiometer value: 120 Ω

Relay output

Relay	Switching voltage max.	Switching current max.	Switching performance max.
2x changeover	250 VAC / 110 VDC	1 A	150 VA / 30 W
4x normally open	250 VAC / 50 VDC	0.2 A	30 VA / 6 W

Electronic outputs

Outputs	Switching voltage max.	Switching current max.	
PNP	50 VDC	50 mA	

Analog output

Output	Range	Resolution	Load resistance
Current	4...20 mA	12 bit	Max. 500 Ω
Voltage	0...10 V	12 bit	Min. 10 kΩ

Scaling configurable relating to value display, accuracy ±0.1 %, transformation 200/s

Terminal assignment

Inputs

Supply voltage

Terminal	Assignment VAC	Assignment VDC
1	Supply voltage	+
2	Ground	n.c.
3	Supply voltage	-

Control inputs

Terminal	Assignment
1	Reset*
2	Hold*
3	Common
4	Tare*
5	Min - Max*

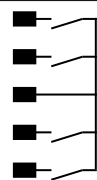

* Default; more functionality assignment options in programming level.

Analog inputs / process

Terminal	Assignment
1	IN + (mV), 1 V, potentiometer
2	IN +5 V, 10 V
3	IN -
4	IN + mA
5	Sensor supply + (2.2 V, 5 V, 10 V, 24 V)
6	Sensor supply -

Outputs

Analog output

Terminal	Assignment
1	(+) 4...20 mA / 0...10 V
2	(-) 4...20 mA / 0...10 V

Interface

Terminal	Assignment RS232	RS485
1	n.c.	-
2	TxD	n.c.
3	RxD	T,R B
4	GND	T,R A
5	-	GND
6	-	-

Limit outputs / electronic PNP outputs

Terminal	Assignment
1	Opto-output 1
2	Opto-output 2
3	Opto-output 3
4	Opto-output 4
5	n.c.
6	Max. +50 VDC

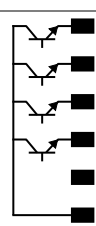

Limit outputs / two relays

Terminal	Assignment
1	Normally open
2	Changeover
3	Normally closed
4	Normally open
5	Changeover
6	Normally closed

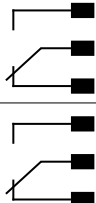

Limit outputs / four relays

Terminal	Assignment
1	Normally open 1
2	Normally open 2
3	Normally open 3
4	Normally open 4
5	n.c.
6	Common

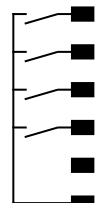

Process displays

For standard signals, strain gauge

PA440

Dimensions

PA440 - without clip frame

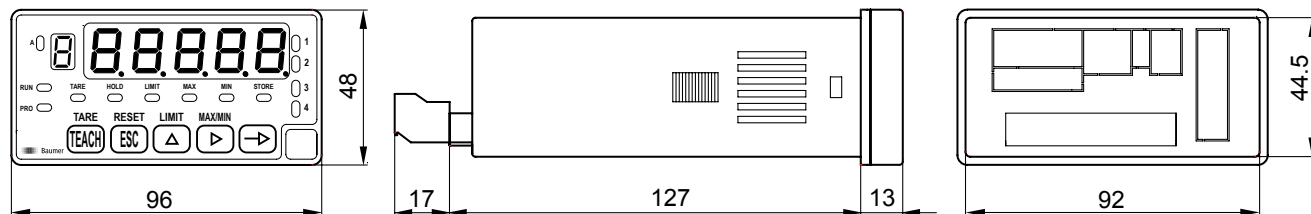

PA440 - clip frame mounting

