

GM400

Solid shaft with clamping flange

Optical multiturn encoders up to 14 bit ST / 16 bit MT

Overview

- Encoder multiturn / SSI
- Optical sensing method
- Resolution: max. singleturn 14 bit, multiturn 16 bit
- Clamping flange
- Electronic setting of zero point
- Counting direction input
- Available with additional incremental output
- Maximum resistant against magnetic fields

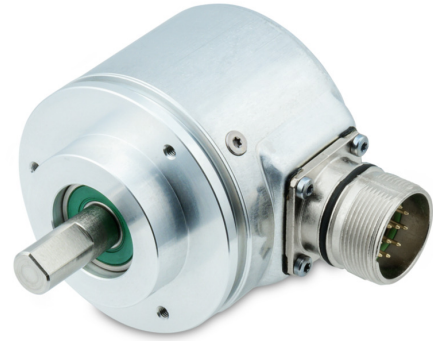

Technical data

Technical data - electrical ratings

Voltage supply	10...30 VDC 5 VDC \pm 10 %
Reverse polarity protection	Yes (10...30 VDC) / No (5 VDC)
Consumption w/o load	\leq 50 mA (24 VDC) \leq 80 mA (5 VDC)
Initializing time typ.	20 ms after power on
Interface	SSI Incremental A 90° B (optional)
Function	Multiturn
Steps per revolution	\leq 16384 / 14 bit
Number of revolutions	\leq 65536 / 16 bit
Absolute accuracy	\pm 0.025 °
Sensing method	Optical
Code	Gray or binary
Code sequence	CW/CCW coded by connection
Inputs	SSI clock Control signals UP/DOWN inv. and zero
Output stages	SSI data: Linedriver RS422 Diagnostic outputs push-pull
Incremental output	512, 1024, 2048 pulses + inverted
Interference immunity	EN 61000-6-2
Emitted interference	EN 61000-6-4
Diagnostic function	Self-diagnosis Multiturn sensing
Approval	UL approval / E63076

Technical data - mechanical design

Size (flange)	\varnothing 58 mm
Shaft type	\varnothing 10 mm solid shaft
Flange	Clamping flange
Protection EN 60529	IP 54 (without shaft seal) IP 65 (with shaft seal)
Operating speed	\leq 10000 rpm (mechanical) \leq 6000 rpm (electric)
Starting acceleration	\leq 1000 U/s ²
Starting torque	\leq 0.015 Nm (+25 °C, IP 54) \leq 0.03 Nm (+25 °C, IP 65)
Rotor moment of inertia	20 gcm ²
Admitted shaft load	\leq 20 N axial \leq 40 N radial
Material	Housing: aluminium Flange: aluminium
Operating temperature	-25...+85 °C -40...+85 °C (optional)
Relative humidity	95 % non-condensing
Resistance	EN 60068-2-6 Vibration \pm 0.75 mm - 10-58 Hz 10 g - 58-2000 Hz EN 60068-2-27 Shock 200 g, 6 ms
Weight approx.	400 g
Connection	Connector M23, 12-pin Connector M12, 8-pin Cable 1 m

Optional

- Stainless steel design
- Corrosion protection for offshore applications

GM400

Solid shaft with clamping flange

Optical multiturn encoders up to 14 bit ST / 16 bit MT

Terminal assignment

Cable or connector M23

Pin	Core colour	Assignment
1	brown	UB
2	black	GND
3	blue	Clock+
4	beige	Data+
5	green	Zero setting
6	yellow	Data-
7	violet	Clock-
8	brown/yellow	DATAVALID inv.
9	pink	UP/DOWN inv.
10	black/yellow	DATAVALID MT inv.
11-12	–	–

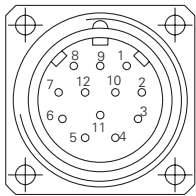

Please use cores twisted in pairs (for example clock+ / clock-) for extension cables of more than 10 m length.

Cable or connector M23 with incremental tracks

Pin	Core colour	Assignment
1	brown	UB
2	white	GND
3	blue	Clock+
4	green	Data+
5	grey	Zero setting
6	yellow	Data-
7	red	Clock-
8	red/blue	Track B inv.
9	pink	UP/DOWN inv.
10	violet	Track A inv.
11	black	Track A
12	grey/pink	Track B

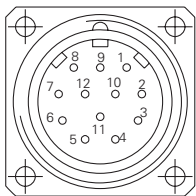

Please use cores twisted in pairs (for example clock+ / clock-) for extension cables of more than 10 m length.

Terminal assignment

Cable or connector M23 with SinCos

Pin	Core colour	Assignment
1	brown	UB
2	white	GND
3	blue	Clock+
4	green	Data+
5	grey	Zero setting
6	yellow	Data-
7	red	Clock-
8	red/blue	Cosine inv.
9	pink	UP/DOWN inv.
10	violet	Sine inv.
11	black	Sine
12	grey/pink	Cosine

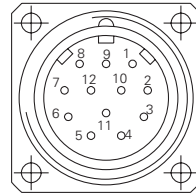

Please use cores twisted in pairs (for example clock+ / clock-) for extension cables of more than 10 m length.

Connector M12

Pin	Assignment
1	GND
2	UB
3	Clock+
4	Clock-
5	Data+
6	Data-
7	Zero setting
8	UP/DOWN inv.

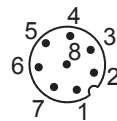

Please use cores twisted in pairs (for example clock+ / clock-) for extension cables of more than 10 m length.

GM400

Solid shaft with clamping flange

Optical multiturn encoders up to 14 bit ST / 16 bit MT

Terminal significance

UB	Encoder voltage supply.
GND	Encoder ground connection relating to UB.
Data+/Data-	Differential SSI data output.
Clock+/Clock-	Differential SSI clock input. Optocoupler or RS422 input.
Zero setting	Input for setting a zero point anywhere within the encoder resolution. The zero setting operation is triggered by a High impulse and has to be in line with the selected direction of rotation (UP/DOWN inv.). Connect to GND after setting operation for maximum interference immunity. Impulse duration ≥ 100 ms.
DATAVALID inv.	Diagnostic output. An error warning is given at level Low.
DATAVALID MT inv.	Diagnostic output for monitoring the multiturn sensor voltage supply. Upon dropping below a defined voltage level the DV MT inv. output is switched to Low.
UP/DOWN inv.	UP/DOWN inv. counting direction input. This input is standard on High. UP/DOWN inv. means ascending output data with clockwise shaft rotation when looking at flange. UP/DOWN inv.-Low means ascending values with counterclockwise shaft rotation when looking at flange.
Incremental Outputs	Incremental tracks A 90° B and inverted.

Output signals

Push-pull and RS422

A leading B when rotating the shaft clockwise and looking at flange.

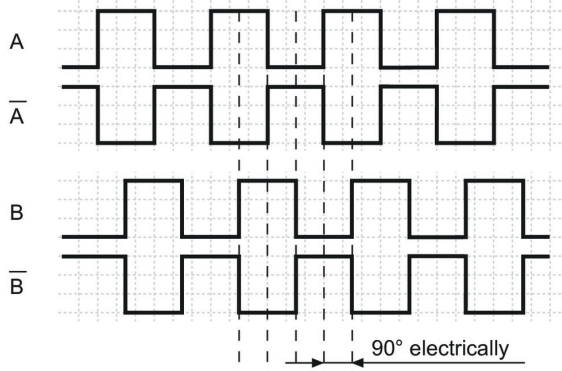

SinCos

Sin leading Cos when rotating the shaft clockwise and looking at flange.

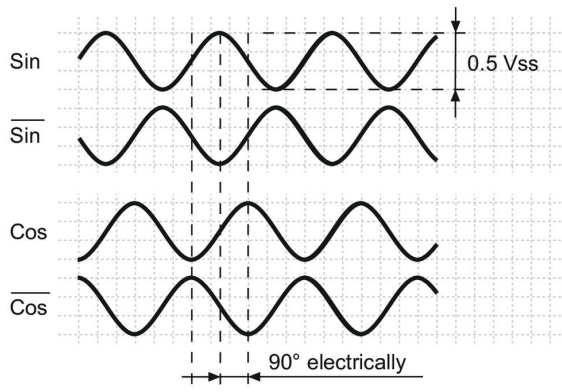

GM400

Solid shaft with clamping flange

Optical multiturn encoders up to 14 bit ST / 16 bit MT

Trigger level

SSI	Circuit
SSI-Clock	Optocoupler with switching current approx. 7 mA or RS422 with terminating resistor
SSI-Data	Linedriver RS422 or RS485

Control inputs	Input circuit
Input level High	>0.7 UB
Input level Low	<0.3 UB
Input resistance	10 kΩ

Diagnostic outputs or Incremental outputs	Output circuit Push-pull circuit-proof
Output level High	>UB -3.5 V (I = -20 mA)
Output level Low	<0.5 V (I = 20 mA)
Load High / Low	<20 mA

Incremental outputs	Linedriver RS422
Output level High	>2.5 V (I = -20 mA)
Output level Low	<0.5 V (I = 20 mA)
Load High / Low	<20 mA

Outputs	SinCos
Output level	0.5 Vpp ±10 % (Output signals before difference formation)
Load	<10 mA

Data transfer

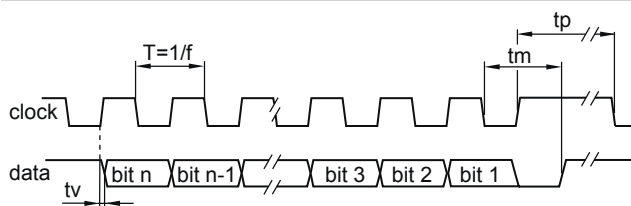

Clock frequency f	62.5...1500 kHz
Duty cycle of T	40...60 %
Delay time tv	150 ns
Monoflop time tm	26 μs + T/2
Clock interval tp	30 μs

GM400

Solid shaft with clamping flange

Optical multiturn encoders up to 14 bit ST / 16 bit MT

Dimensions

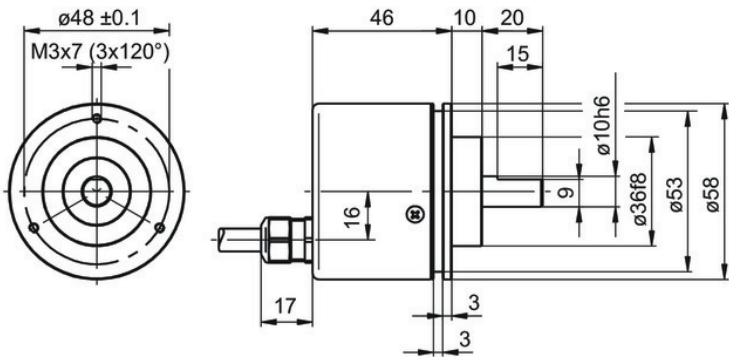

Cable, axial

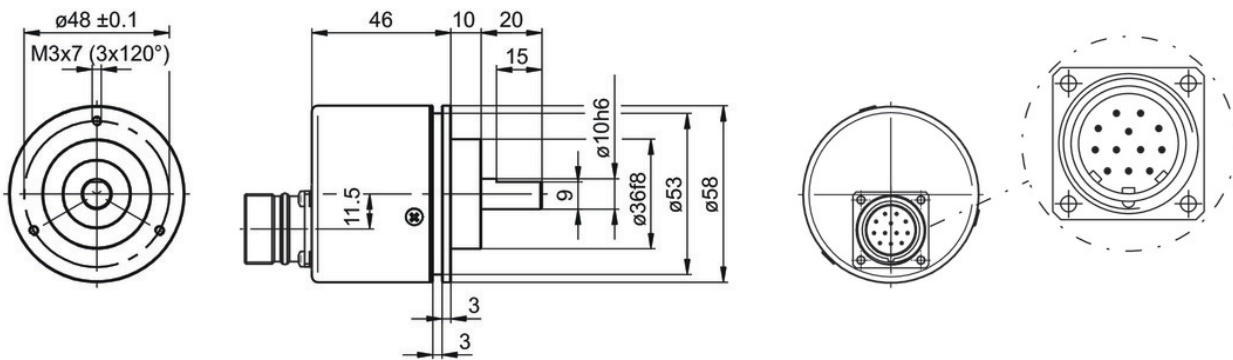

Connector M23, axial

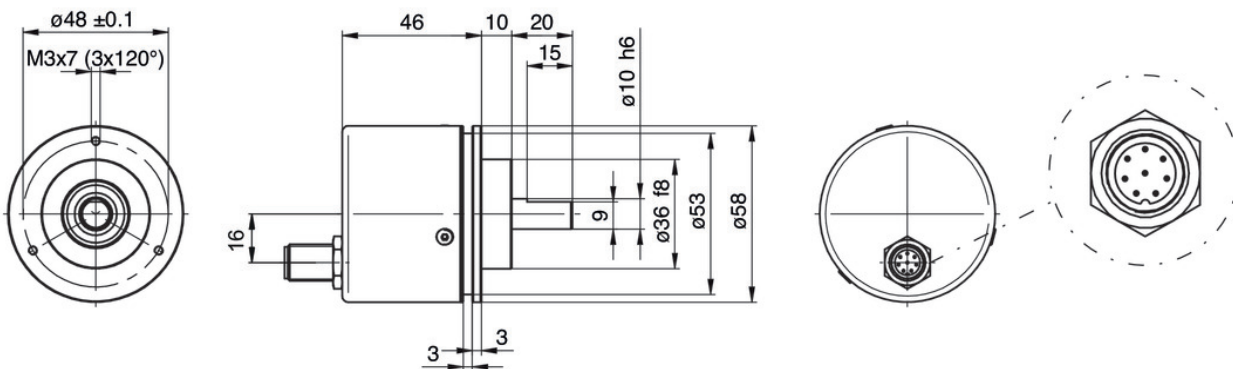

Connector M12, axial

GM400

Solid shaft with clamping flange

Optical multiturn encoders up to 14 bit ST / 16 bit MT

Dimensions

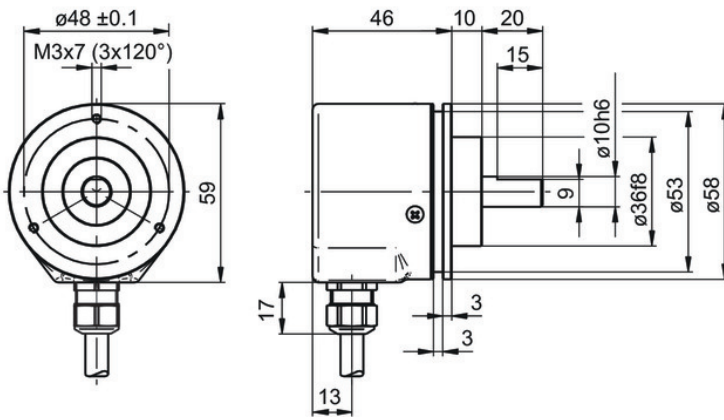

Cable, radial

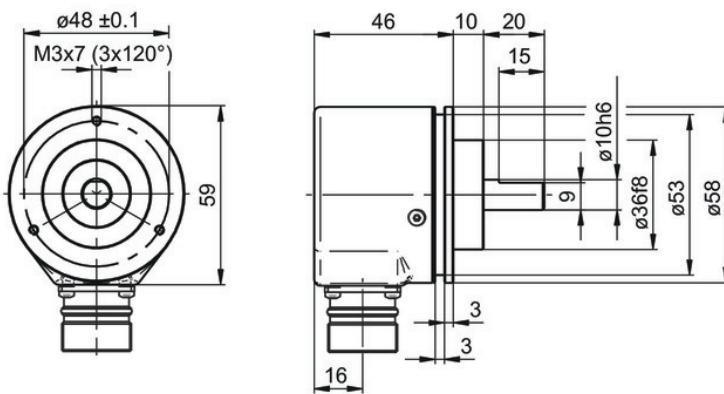
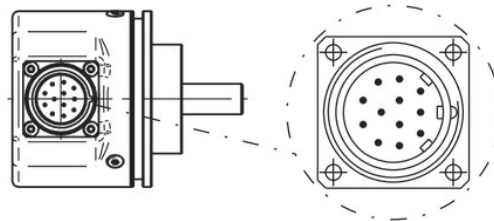

Connector M23, radial

GM400

Solid shaft with clamping flange

Optical multiturn encoders up to 14 bit ST / 16 bit MT

Dimensions

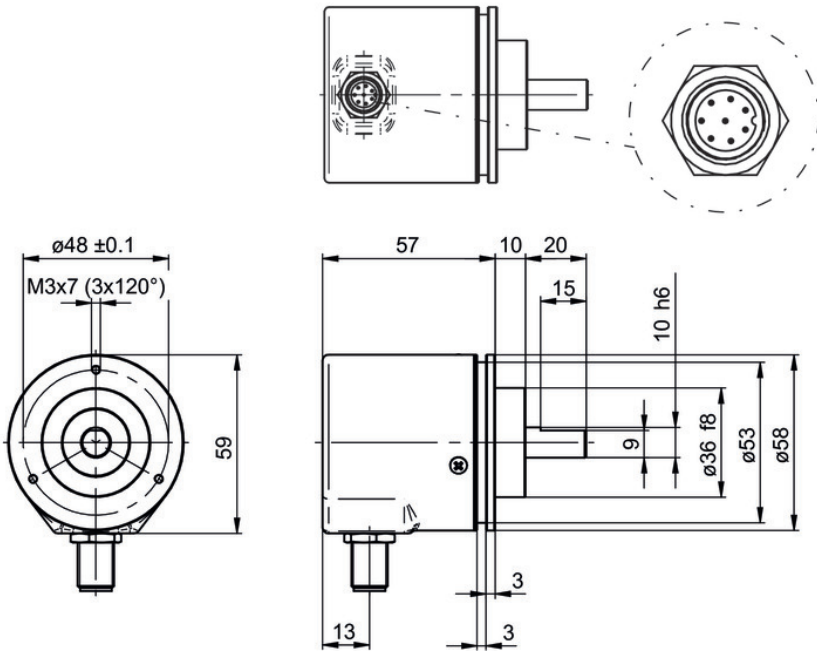

Connector M12, radial

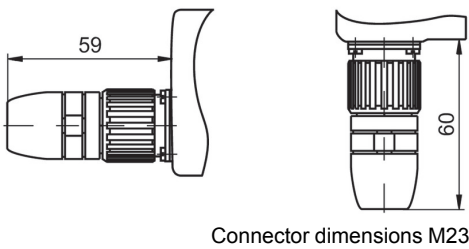

Connector dimensions M23

GM400

Solid shaft with clamping flange

Optical multiturn encoders up to 14 bit ST / 16 bit MT

Ordering reference

	GM400.	#	###	##	##
Product	GM400.				
Flange / Solid shaft					
Clamping flange, ø10 mm, IP 54		0			
Clamping flange, ø10 mm, IP 65		A			
Voltage supply / Signals					
10...30 VDC, Gray code 25 bit (ST 13 + MT 12)			10		
5 VDC, Gray code 25 bit (ST 13 + MT 12)			11		
10...30 VDC, binary code 25 bit (ST 13 + MT 12)			12		
5 VDC, binary code 25 bit (ST 13 + MT 12)			13		
10...30 VDC, Gray code 24 bit (ST 12 + MT 12)			20		
10...30 VDC, Gray code 25 bit (ST 13 + MT 12) + parity bit			30		
10...30 VDC, Gray code 24 bit (ST 12 + MT 12) + DV bit			40		
10...30 VDC, Gray code 26 bit (ST 14 + MT 12)			90		
10...30 VDC, binary code 26 bit (ST 14 + MT 12)			92		
10...30 VDC, Gray code 29 bit (ST 13 + MT 16)			A0		
Connection					
Cable axial, 1 m					11
Cable radial, 1 m					21
Cable 1 m, axial, for incremental output					31
Cable 1 m, radial, for incremental output					41
Flange socket M23, axial, 12-pin, male contacts, CW					A0
Flange socket M23, radial, 12-pin, male contacts, CW					A1
Flange socket M23, axial, 12-pin, male contacts, CW, for incremental output					A2
Flange socket M23, radial, 12-pin, male contacts, CW, for incremental output					A3
Flange socket M12, axial, 8-pin, male contacts, A-coded					M4
Flange socket M12, radial, 8-pin, male contacts, A-coded					M5
Pulses / Incremental output					
No incremental output					02
2048 pulses, push-pull					04
2048 pulses, RS422					06
2048 periods, SinCos 1 Vpp ⁽¹⁾					07
1024 pulses, push-pull ⁽¹⁾					24
1024 pulses, RS422 ⁽¹⁾					26
1024 periods, SinCos 1 Vpp ⁽²⁾					27
512 pulses, push-pull ⁽²⁾					34
512 pulses, RS422 ⁽²⁾					36
512 periods, SinCos 1 Vpp ⁽²⁾					37

(1) Version with 5 VDC on request

(2) On request

GM400

Solid shaft with clamping flange

Optical multiturn encoders up to 14 bit ST / 16 bit MT

Accessories

Mounting accessories

10117669	Eccentric fixing, single (Z 119.006)
10141255	Adaptor plate for clamping flange for modification into synchro flange (Z 119.013)
10125051	Mounting adaptor for encoders with clamping flange (M3) (Z 119.017)
10141132	Spring washer coupling D1=6 / D2=10 (Z 121.C01)